



USER MANUAL

Maxxforce GHG17 AdBlue Emulator

EURO 6



 www.canbusemulator.com

 +90 530 937 46 36

 [erenakarsubasi](https://t.me/erenakarsubasi)

Maxforce GHG17 Emulator Installation

Emulator Red	NOx pin1
Emulator Black	NOx pin 4
Emulator Green	NOx pin 2
Emulator Yellow	NOx pin 3
Emulator Brown	Diagnostic Tool Socket Pin "D"
Emulator White	Diagnostic Tool Socket Pin "C"

Emulator Thin Green Cable	DPFDP/DPFOP pin1
Emulator Thin Yellow Cable	DPFDP/DPFOP pin4
Emulator Blue Cable	DPFDP/DPFOP pin2
Emulator Pink Cable	DPFDP/DPFOP pin3

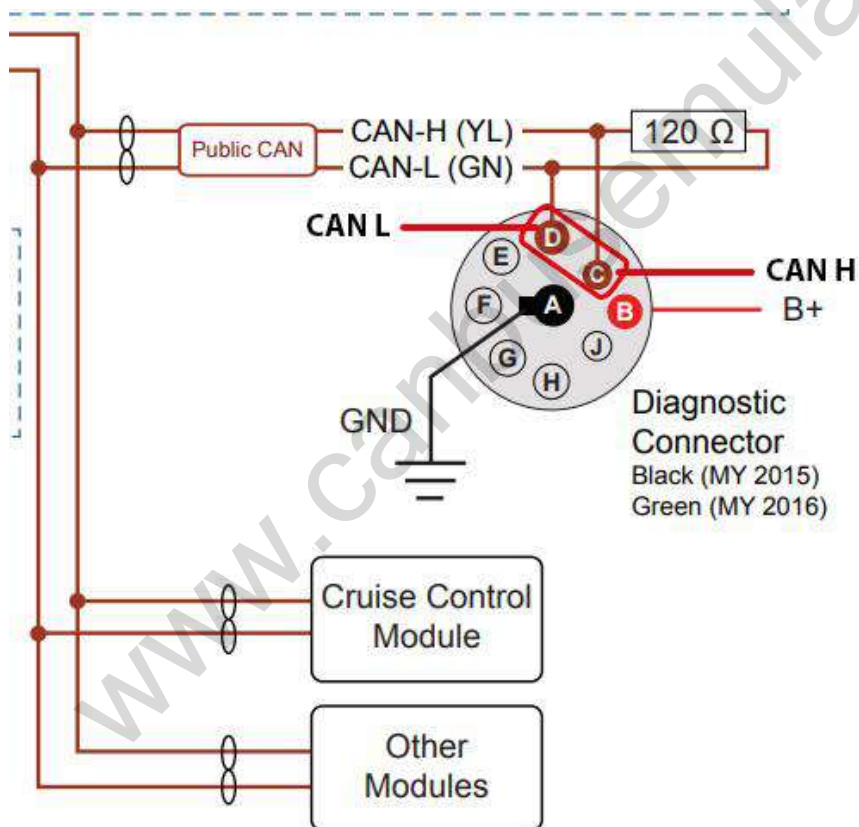

Fuse Not Remove

Maxforce GHG17 Emulator Installation

DPF Remove

You must remove the following sockets in the exhaust system and AdBlue tank installation.

Sockets to be pulled in the exhaust system (marked in the image): NOx , AFT temperature, PM Sensor, DPFDP/ DPFOP sockets should be removed.

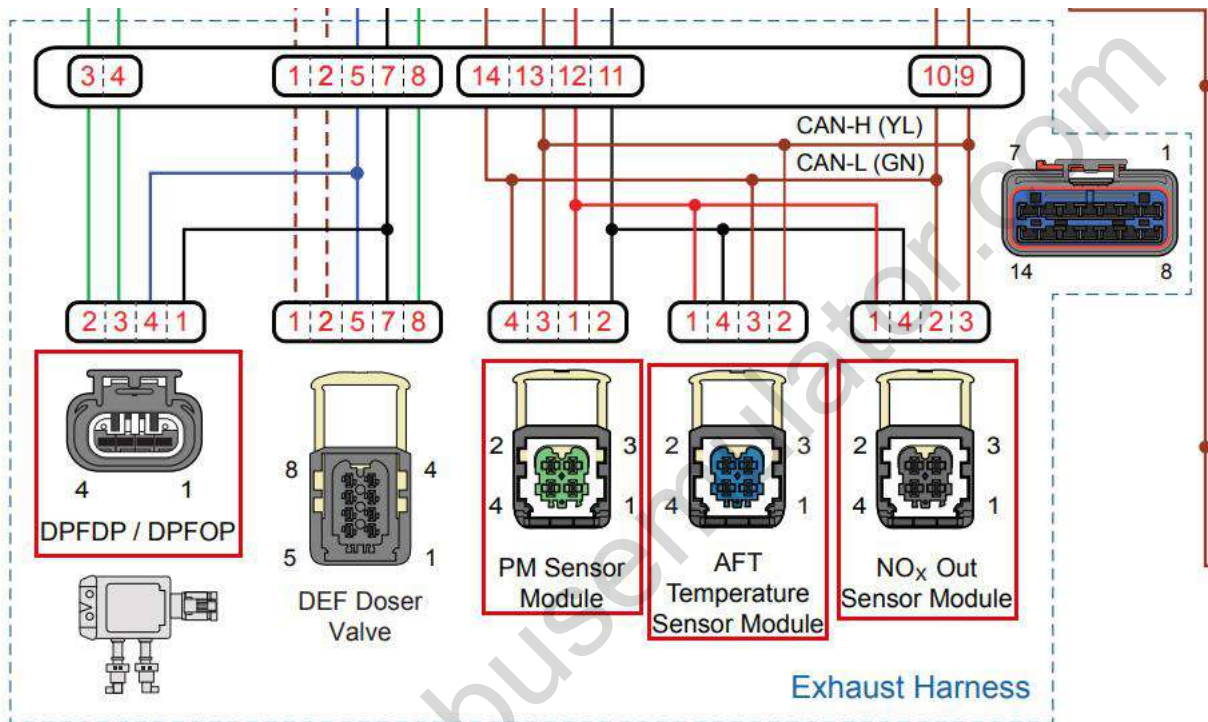

Sockets to be removed in Adblue installation (marked in the image): Adblue level (DEF Head Unit) socket must be removed.

